

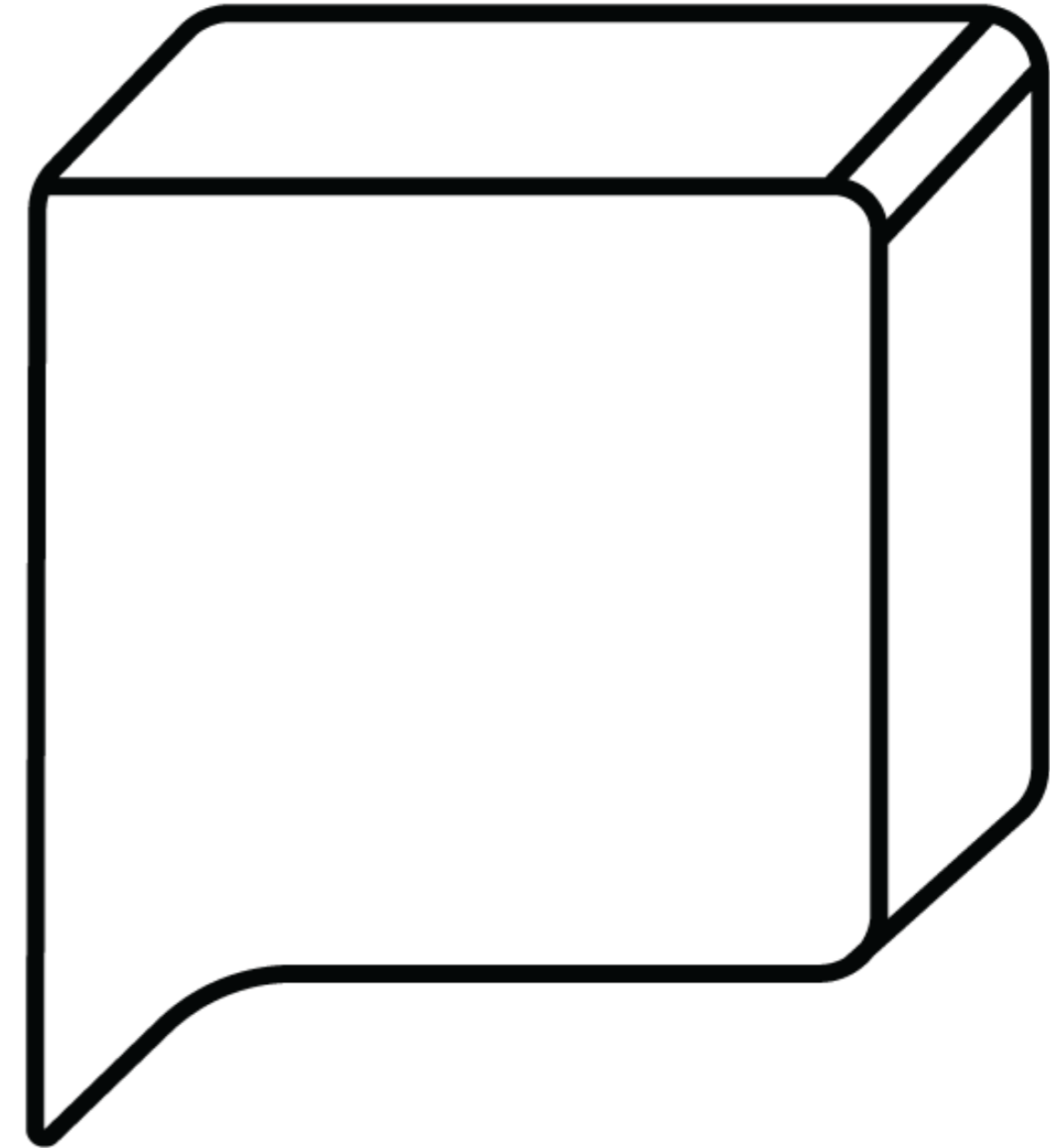

# Youth Pitches Guidelines

طوق  
شبابية  
YOUTH PITCHES



An Initiative by



In Collaboration with



# Pitch Deck

Along with the application form, we also request that the applicants submit their pitch deck, tailored into the template in the next slides (the templates is our basic requirements, however participants can add as long as it does not exceed the criteria below):

## The pitch deck should be:

- Not more than **10 Slides**
- **Presentation can be in English , but pitching will be mainly in Arabic**
- Factual and straight to the point
- States the vision, mission, and the solution to the topic/challenge of the pitch round
- Includes a brief description of the business/working model
- Finally, includes the impact that the pitches is hoping to achieve through their idea/startup



# Pitch Deck Template

ساول  
چايه  
YOUTH PITCHES

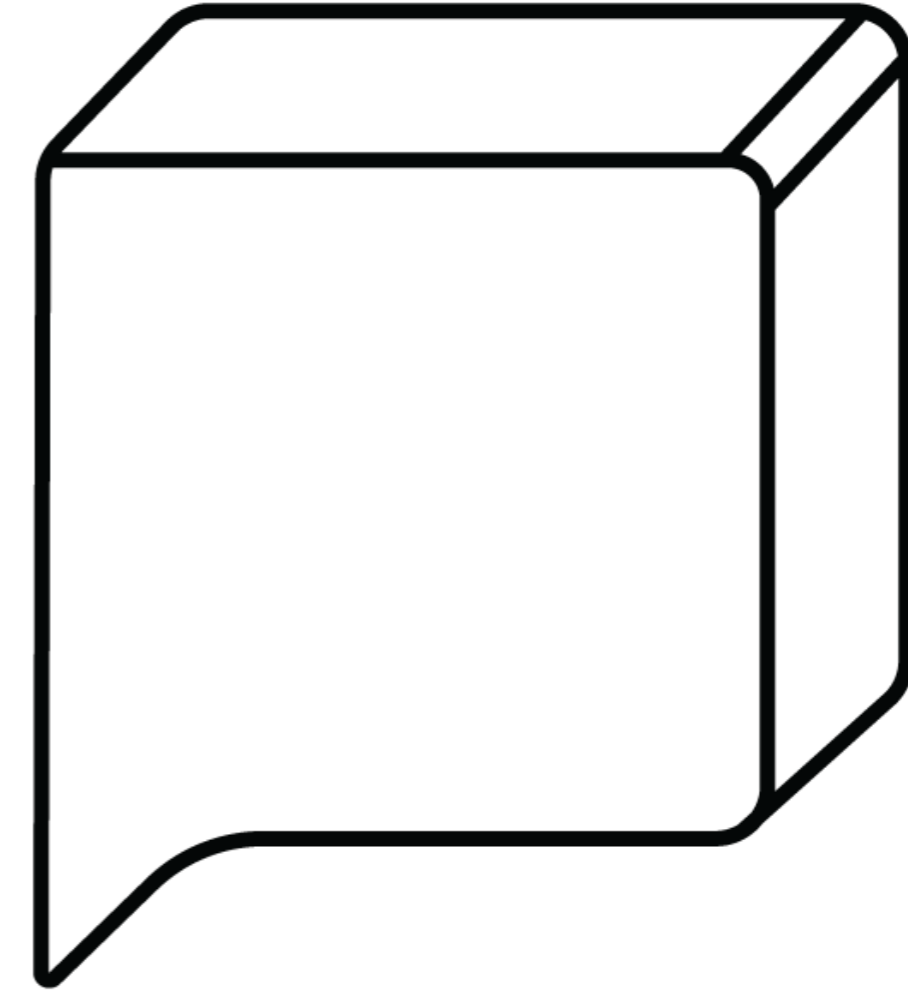

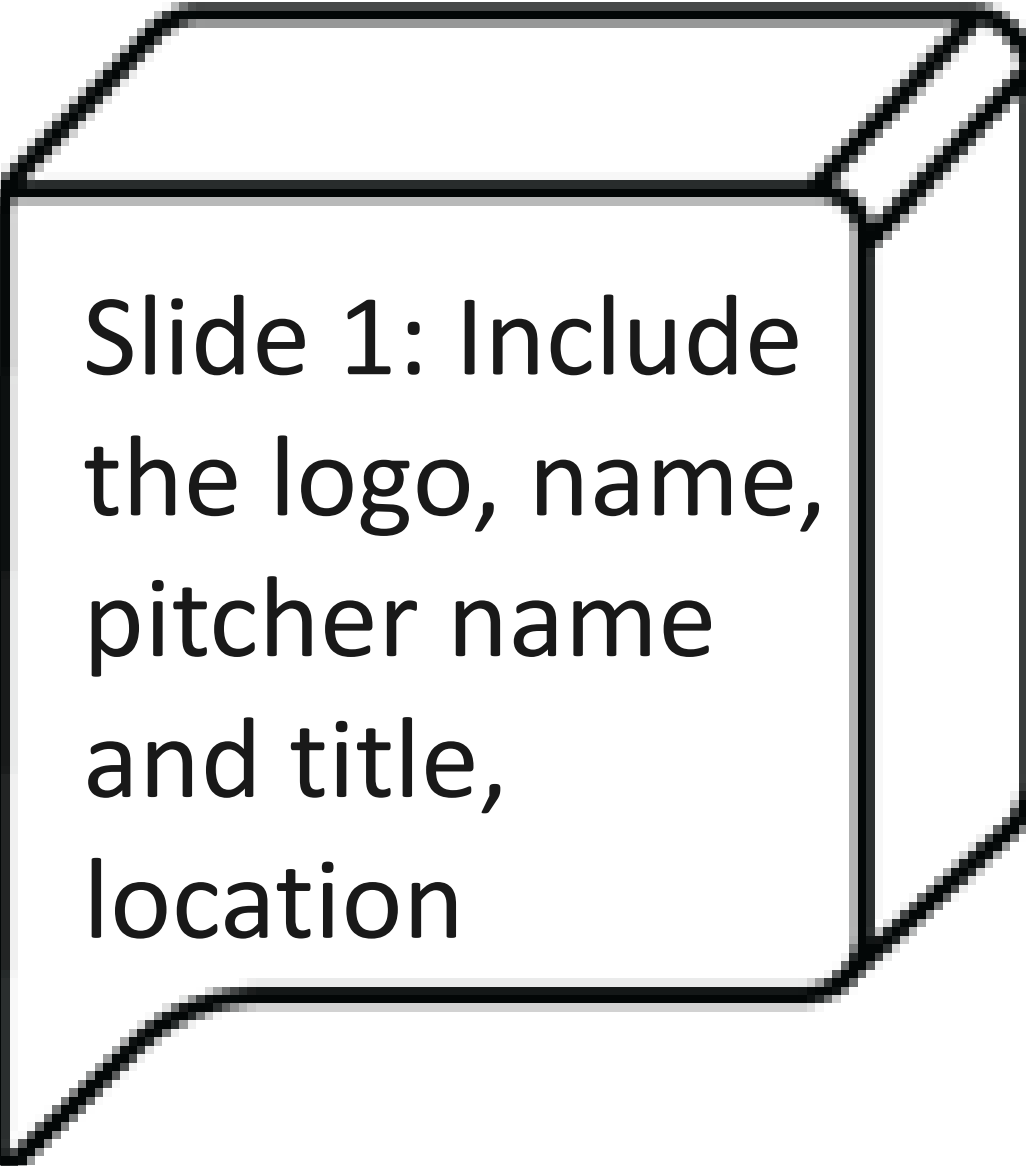

Slide 1: Include  
the logo, name,  
pitcher name  
and title,  
location

Logo

Startup/IDEA Name

Presenter Name & Title

Location

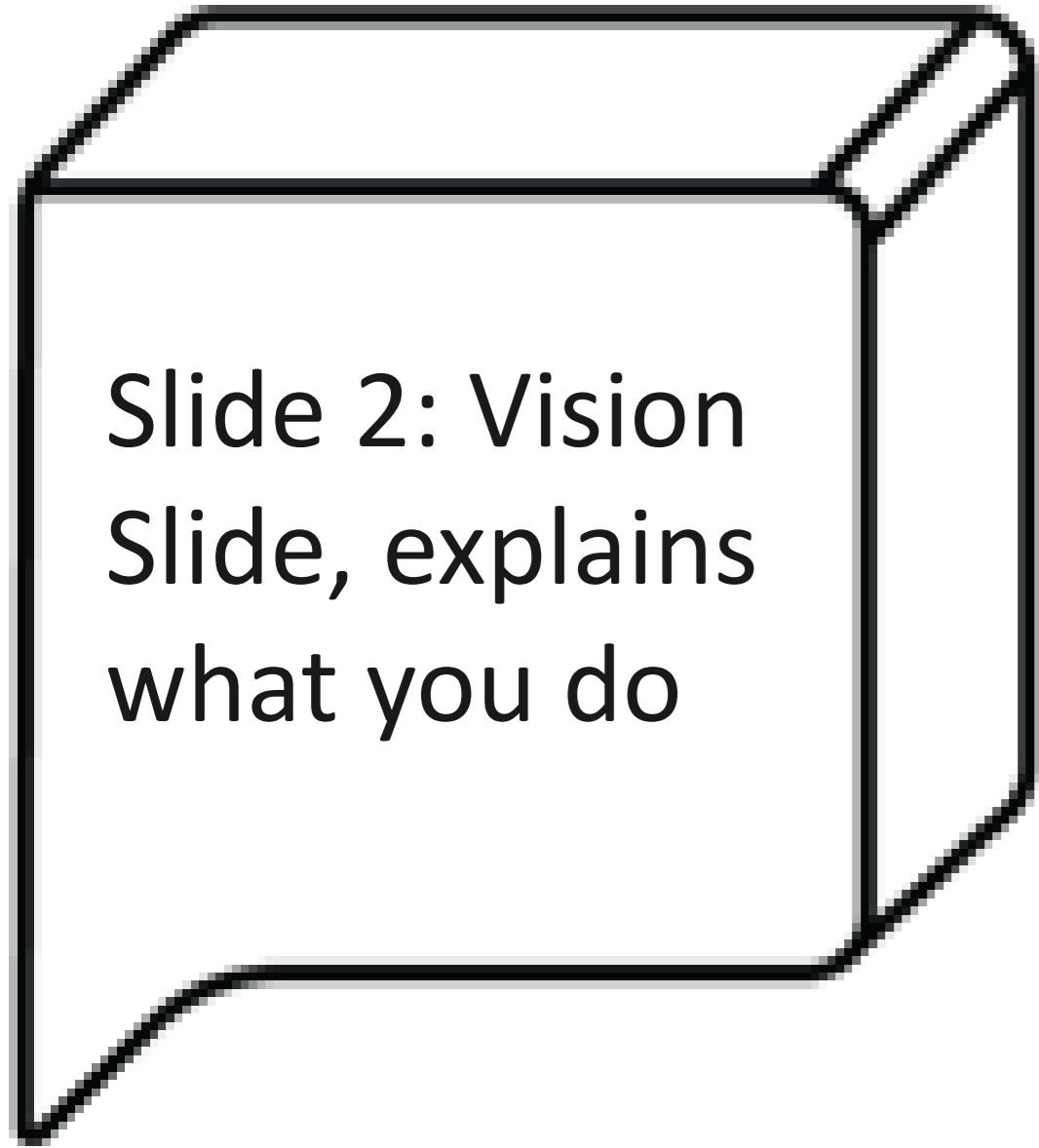

## The Vision

Include explanation, images, etc.

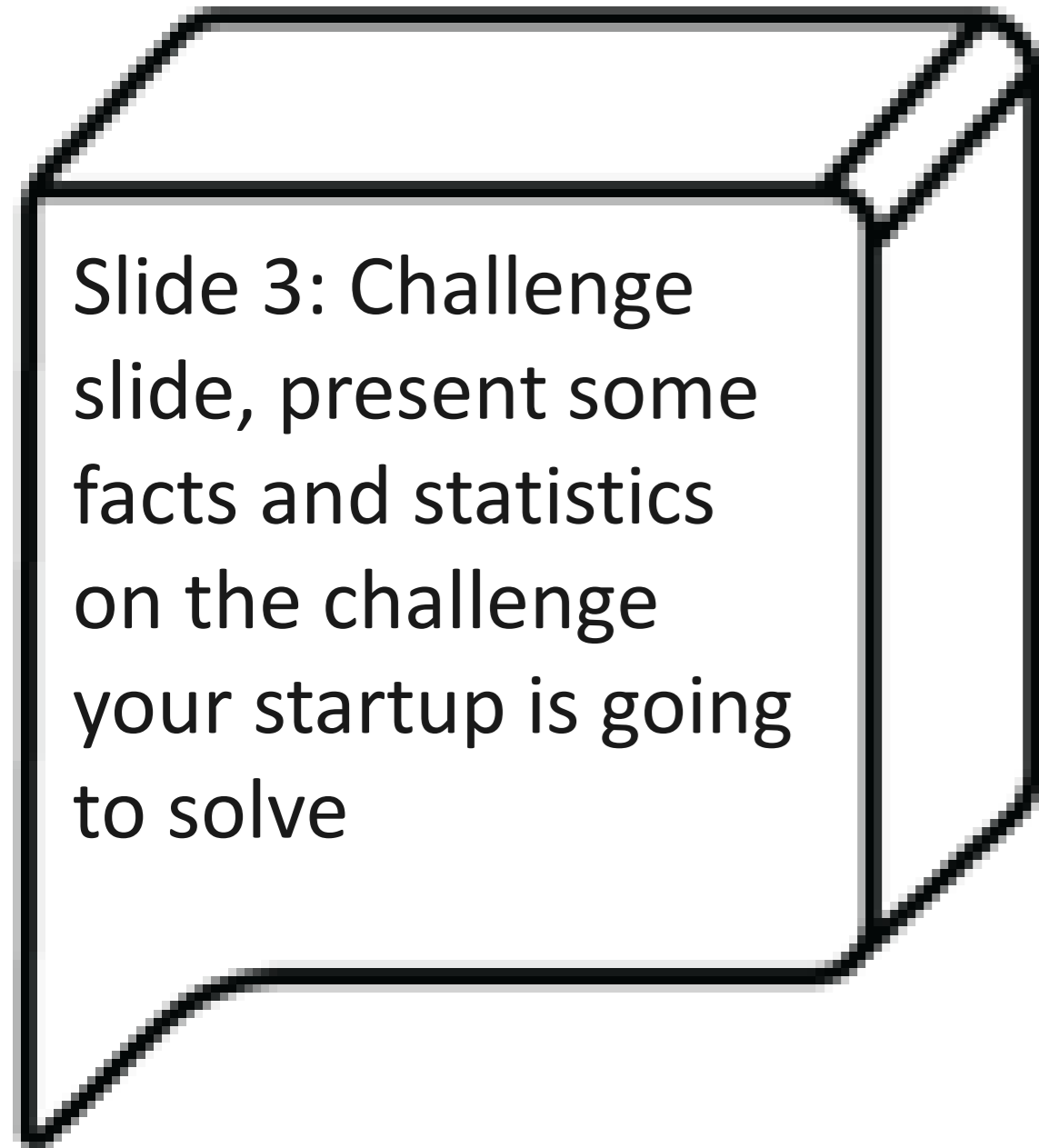

## The Challenge

Present factual information on the challenge that you are solving.

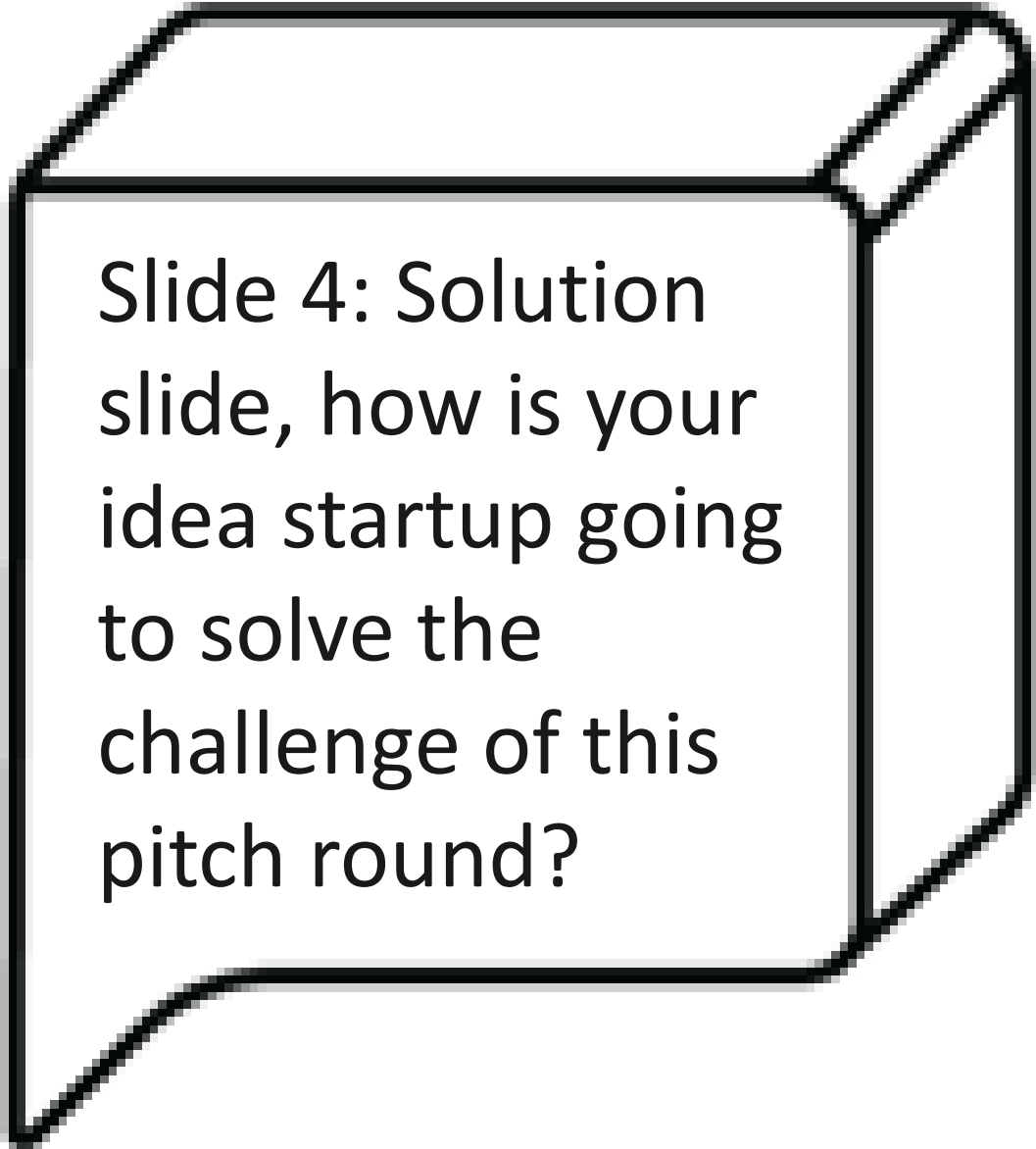

Slide 4: Solution  
slide, how is your  
idea startup going  
to solve the  
challenge of this  
pitch round?

## The Solution

How is your startup/idea a solution to  
this round's challenge? *“in this case,  
women in employment”*

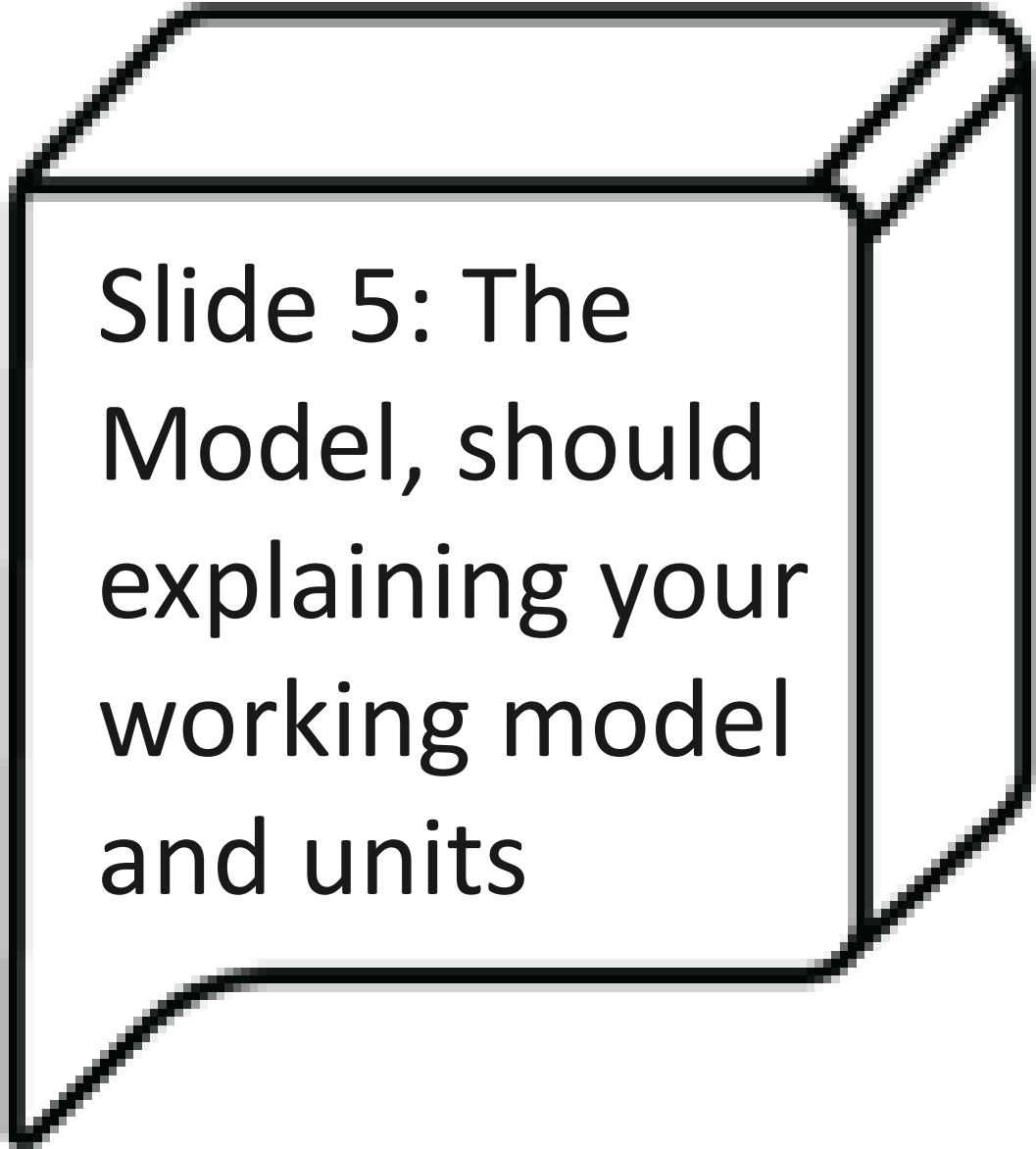

Slide 5: The Model, should explaining your working model and units

## The Model

Explains your operations and needs.



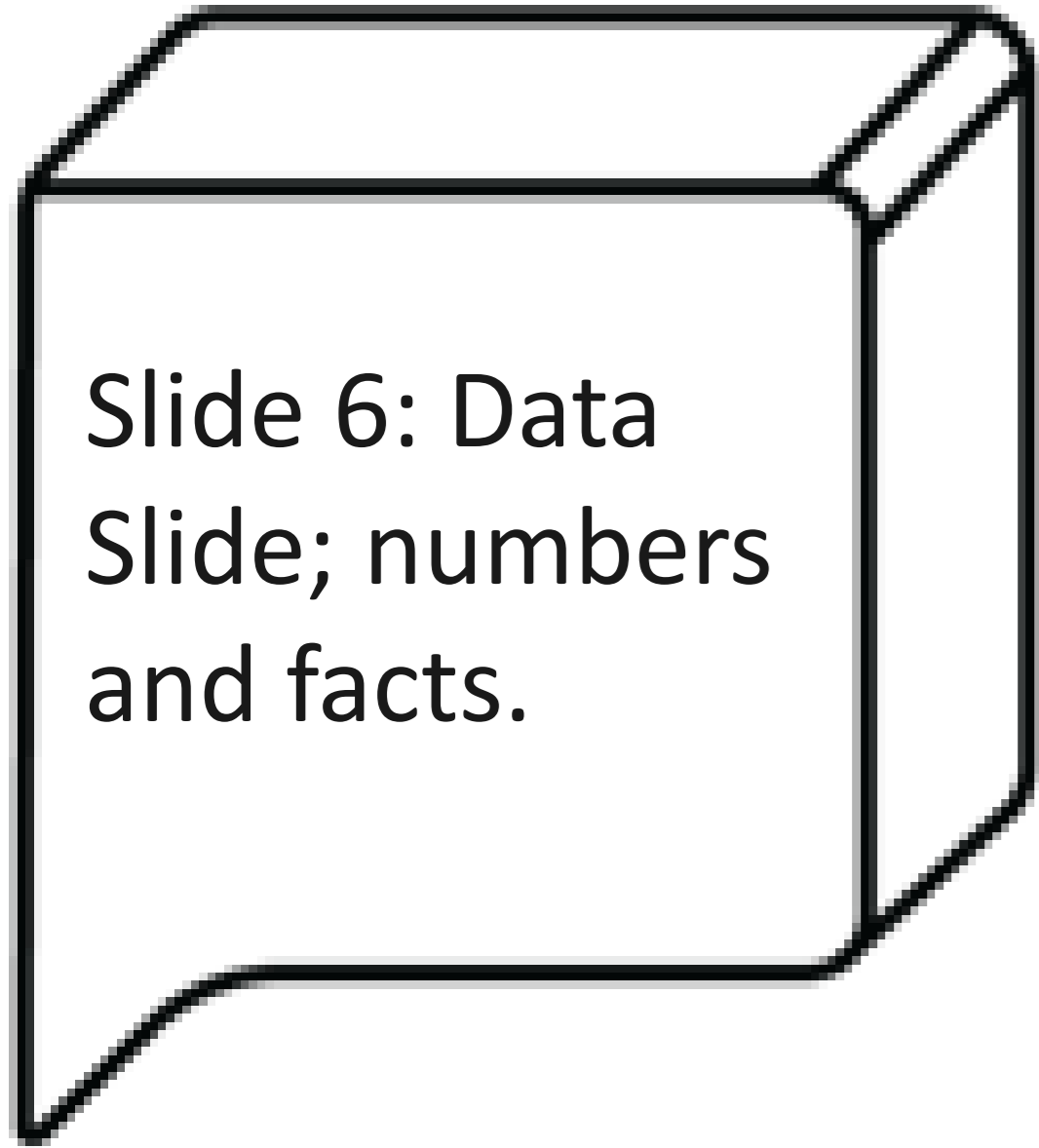

## Data

Provide some empirical proof that the solution works.